

ENGINE

Model	ISM N844T / M3
Type	Diesel 4-stroke, Turbo, I.D.I.
Cylinder	4
Bore/stroke	3.31 x 3.94 in (84 x 100 mm)
Displacement	135 cu in (2.2 L)
Fuel injection	Indirect
Fuel	#2 diesel
Fuel filter	In-line strainer
Air intake	Turbocharged w/ internal EGR
Cooling	Liquid
Engine speeds –	
High idle - no load (rpm)	3080 +/- 50
Rated -full load (rpm)	2900
Low idle (rpm)	1200 +/-50
Horsepower per SAE J1349 –	
Gross	60 hp (44.7 kW) @ 2900 rpm
Net	57 hp (42.1 kW) @ 2900 rpm
Peak torque	126 lb-ft (171 N-m) @ 1800 rpm

ENGINE COOLING

Radiator –	
Core type	All aluminum
Core size area	0.26 m ²
Rows of tubes	43
Cap pressure	16 +/-2 psi
Fan –	
Diameter	17.7 in (450 mm)
Ratio	0.89:1
Water pump	
Style	Centrifugal
Flow	13.2 gpm (50.1 L/min)
Engine lubrication	
Pump	Pressure feed w/ Trichoid pump & plate cooler
Pump operating angle ratings	
Side to side	35°
Bucket up	35°
Bucket down	35°
Oil filtration	Replaceable, full-flow cartridge

POWERTRAIN

Drive pump – Mechanical	
Pump to engine ratio	1:1
Displacement	2.14 cu in (35 cc)
Flow at rated engine rpm	
@100% efficiency	26.9 gpm (102 L/min)
Charge pressure	363 psi (25 bar)
System relief	5,000 psi (345 bar)
Control	Direct Mechanical
Drive pump – Electro Hydraulic	
Pump to engine ratio	1:1
Displacement	2.14 cu in (35 cc)
Flow at rated engine rpm	
@100% efficiency	26.9 gpm (102 L/min)
Charge pressure	363 psi (25 bar)
System relief	5220 psi (360 bar)
Control	Electro Hydraulic
Drive motors –	
Max. displacement –	19.83 cu in (325 cc)
Displacement – optional	
High speed cc (cu in)	12.2 cu in (200 cc)
Speed @ high idle engine rpm	
(100% eff. at rated engine rpm)	313
Speed @ optional high speed rpm	509
Torque @ max displacement and relief pressure (calculated)	1,316 lb-ft (1784 N-m)
Travel speed –	
Low range	7.4 mph
High range (optional)	11.5 mph
Final drive	Single-Reduction chain drive
Drive chain –	
Size	ASA #80
Tensile strength	21,000 lb (93.4 KN)
Axles –	
Torque @ max displacement and relief pressure (calculated)	4,868 lb-ft (6600 N-m)
Diameter	2 in (50.48 mm)
Length	15.1 in (384 mm)
Parking Brake	
Type	Spring-applied, hydraulic release disc
Engagement	Depress on/off brake button on handle or instrument panel, raise seat bar, get off seat, or stop engine

HYDRAULIC SYSTEM

Standard equipment pump –	
Type	Gear
Displacement –	
Standard aux.	1.52 cu in (24.9 cc)
High flow aux.	0.76 cu in (12.5 cc)
Pump flow @ rated engine rpm	
@ 100 % efficiency	19 gpm (72 L/min)
Optional high flow @ rated engine rpm	
@ 100 % efficiency	9.5 gpm (36 L/min)
Loader control valve –	
Type	3 Spool / Open Center / Series
Relief pressure	3000 (+145/-0) PSI (207 Bar)
Port relief pressures –	
Loader raise	3,263 psi (225 bar)
Bucket dump	3,481 psi (240 bar)
Bucket curl	3,336 psi (230 bar)
Hydraulic lines –	
Tubing	37° JIC Flare
Loop hoses	SAE 100 R13
Hydraulic oil cooler –	
Number of fins	10 per inch (3.94 per cm)
Number of tubes	9
Area	137.5 sq in (887 cm ²)
Hydraulic filter	6 micron / Spin on

INSTRUMENTATION

Indicators
Digital Hourmeter
Fuel level LCD bar graph with alarm
Warning lights with alarms
Engine coolant temperature
Engine oil pressure
Engine Malfunction
Hydraulic charge pressure
Hydraulic filter restriction
Hydraulic oil temperature
Warning alarms
Battery voltage (plus display)
Indicator light
Engine preheat
Parking brake
Seat bar reminder

ELECTRICAL SYSTEM

Alternator 95 amp
Starter 2.2 kW
Battery
12-volt low-maintenance 1000 cold-cranking amps @ 0° F (-18° C)

OPERATOR ENVIRONMENT

ROPS/FOPS level 1 canopy w/side screens
Tilt ROPS/FOPS
Rear window w/ emergency escape
Instrument panels
Suspension vinyl seat
2 in (51 mm) retractable seat belt
Hand throttle
Foot throttle
Alarm package
Headliner
Top window
Cup holder
Power plug socket
Foot rest
Storage tray
Low effort ergonomic hand controls
Padded seat bar w/integral armrests
Loader control lockout system
Electric parking brake control
Floor cleanout panel

CYLINDERS

Lift cylinder –	
Bore diameter	2.25 in (57.2 mm)
Rod diameter	1.5 in (38.1 mm)
Stroke	31.7 in (804.9 mm)
Closed length	45.6 in (1158.0 mm)
Bucket cylinders –	
Bore diameter	2.75 in (69.9 mm)
Rod diameter	1.375 in (34.9 mm)
Stroke	16.14 in (410.0 mm)
Closed length	24 in (610.0 mm)

WEIGHTS

Operating weight	6,200 lb (2812 kg)
Shipping weight	5,900 lb (2675 kg)
Add-on weights –	
Side cab glass	46.9 lb (21.3 kg)
Lexan door	74 lb (33.6 kg)
Glass door with wiper	134 lb (60.8 kg)
Suspension seat	22.1 lb (10 kg)

SERVICE CAPACITIES

Fuel tank	20 gal (75.5 L)
Engine oil with filter	9 qt (8.5 L)
Hydraulic system –	
Reservoir	5.3 gal (20 L)
Total	NA
Chain tanks (per side)	7.1 qt (6.7 L)

TIRE SELECTION

	Size	Ply Rating	Tread Depth	Tire Width	Tread Width	Width Over Tires	Tire Weight*
Heavy-Duty	10 x 16.5	–	–	–	53 (1348)	64 (1627)	–
Premium	10 x 16.5	–	–	–	53 (1348)	64 (1627)	–
Premium - Lined	10 x 16.5	–	–	–	53 (1348)	64 (1627)	–
Severe Duty	10 x 16.5	–	–	–	53 (1348)	64 (1627)	–
Non-Pneumatic	10 x 16.5	–	–	–	53 (1348)	64 (1627)	–
Heavy-Duty	12 x 16.5	–	–	–	57 (1465)	70 (1785)	–
Premium	12 x 16.5	–	–	–	57 (1465)	70 (1785)	–
Premium - Lined	12 x 16.5	–	–	–	57 (1465)	70 (1785)	–

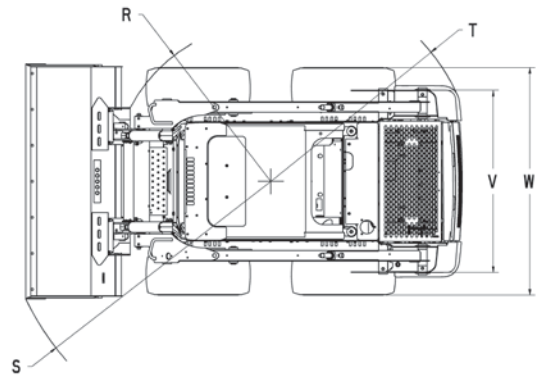
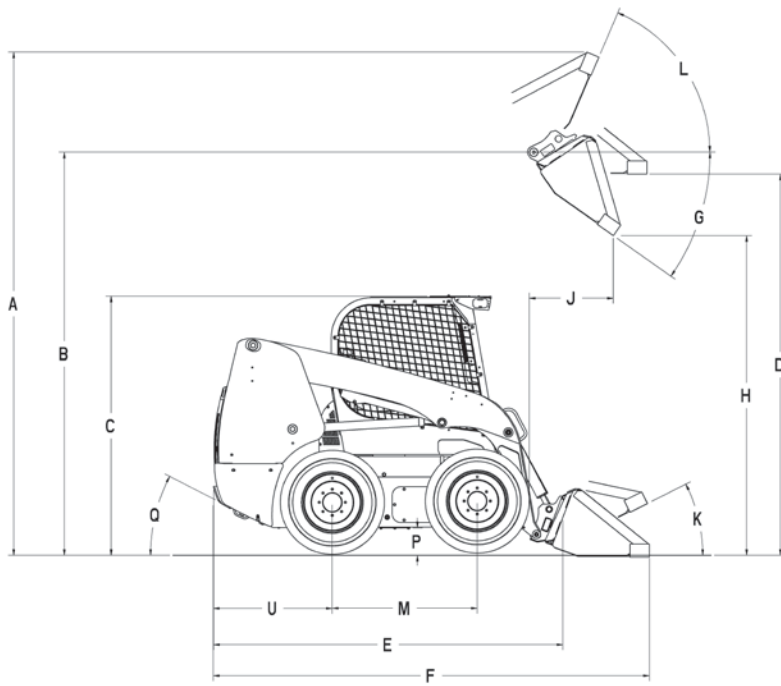

DIMENSIONS

A. Overall operating height - in (m) –	
with foundry/excavating bucket short lip	153.4 (3.90)
with low profile/standard lip bucket	157.3 (4.0)
with low profile extended / long lip bucket	162.2 (4.1)
Height to - in (m) –	
B. Bucket hinge pin	122 (3.10)
C. Top of ROPS	77.7 (1.97)
D. Bottom of level bucket, fully raised	115.2 (2.9)
Overall length - in (m) –	
E. without attachment with coupler	105.7 (2.69)
F. with foundry excavation bucket on ground	130.1 (3.3)
with low profile bucket	134.3 (3.4)
with low profile extended bucket	139.3 (3.5)
G. Dump angle	39.6°
H. Dump height - in (m) –	
with foundry/excavating bucket short lip	97.2 (2.47)
with low profile/standard lip bucket	94.6 (2.4)
with low profile extended bucket	NA
J. Dump reach (max. height) - in (m)	21.3 (0.54)
Maximum attachment rollback –	
K. Bucket on ground	31.6°
L. Bucket at full height	98.6°
M. Wheelbase - in (m)	44.4 (1.13)
P. Ground clearance (bottom of belly pan) - in (m)	7 (0.18)
Q. Angle of departure	22.5°
Clearance circle - in (m) –	
R. Less bucket	50.7 (1.3)
S. with 66-in (1.68m) foundry bucket in carry position	78.4 (2.0)
with 66-in (1.68m) low profile bucket on ground	81.7 (2.1)
with 66-in (1.68m) extended low profile on ground	86.3 (2.2)
T. Clearance circle rear - in (m)	62.9 (1.60)
U. Rear axle to bumper - in (m)	36.4 (0.92)
V. Tread width with spec tires - in (m) –	53.1 (1.35)
W. Over the tire width with spec tires - in (m) –	64.07 (1.63)

PERFORMANCE SPECS

Rated operating load –	
50%	1,750 lb (790 kg)
Tipping load	3,500 lb (1588 kg)
Breakout forces –	
Lift cylinder	4,780 lb (21.3 kN)
Bucket cylinder	7,145 lb (31.8 kN)
Dig depth with bucket flat	0
Cycle times (seconds) –	
Raise	3.5
Lower	2.0
Dump	2.7
Roll back	2.0

OPTIONAL BUCKETS

Type	Width inch (m)	Weight lb (kg)	Heaped Capacity ft ³ (m ³)
Dirt & Foundry	66	370	15.2
	(1.6)	(168)	(0.43)
	72	390	16.7
	(1.8)	(177)	(0.47)
	78	435	18.4
	(2.0)	(197)	(0.52)
Low Profile	66	400	13.2
	(1.6)	(181)	(0.37)
	72	425	14.5
	(1.8)	(193)	(0.41)
Low Profile Extended	66	434	15.5
	(1.6)	(197)	(0.44)
	72	477	17.1
	(1.8)	(216)	(0.48)
	78	502	18.6
	(2.0)	(228)	(0.53)
Light Material	84	607	20.2
	(2.1)	(275)	(0.57)
	72	434	23.7
	(1.8)	(197)	(0.67)
Manure & Slurry	84	497	27.9
	(2.1)	(225)	(0.79)
	72	465	19.1
	(1.8)	(211)	(0.54)
Heavy Duty	84	535	22.5
	(2.1)	(243)	(0.64)
	66	474	13.3
	(1.6)	(215)	(0.37)
	72	501	14.6
	(1.8)	(227)	(0.41)
	78	527	15.9
	(2.0)	(239)	(0.45)

STANDARD EQUIPMENT

OPERATOR'S COMPARTMENT

ROPS/FOPS level 1 canopy w/side screens
Tilt ROPS/FOPS
Rear window w/ emergency escape
Instrument panels
Suspension vinyl seat
2 in (51 mm) retractable seat belt
Hand throttle
Foot throttle
Alarm package
Headliner
Top window
Cup holder
Power plug socket
Foot rest
Storage tray
Low effort ergonomic hand controls
Padded seat bar w/integral armrests
Loader control lockout system
Electric parking brake control
Floor cleanout panel

LOADER

Radial loader arm design
Mechanical attachment coupler
Loader lift arm support strut

ENGINE

ISM N844T / M3 diesel
Integral engine oil cooling
Fuel filter w/water trap
Dual element air cleaner
120 amp alternator
1000 CCA 12-volt battery
Glow plug
Over & under radiator and oil cooler
Spark arresting muffler

POWERTRAIN

Hydrostatic four wheel drive
Servo controlled pumps
ASA #80HS drive chain
SAHR disc parking brakes

HYDRAULICS

Auxiliary hydraulics 3050 psi
(210 bar) – 23.8 gpm (90 L/min)
Hydraulic circuit pedal lock
Loader arm-mounted ISO flat face connectors
Auxiliary function lockout override
Loader function lockout system
Loader lift lockout override
3-spool loader control valve
Heavy-duty oil cooler
Loader arm float position

OTHER

Add-on counterweights
Lockable service access hood
Single-point daily servicing
Halogen lights, 2-front, 2 side, 2-rear (halogen)
Rear tail lights
Remote oil drain

OPTIONAL EQUIPMENT

OPERATOR'S COMPARTMENT

Deluxe cloth suspension seat w/ heater and lumbar support
Interior mirror
Electric auxiliary hydraulic control
Glass front door w/wiper & washer
Sliding side windows
3 inch retractable seat belt
Heater and AC
Radio
Demolition door

LOADER

Auxiliary front electric control
Ride control
Switchable EH controls
Hydraulic attachment coupler
Hydraulic one-way self-leveling

HYDRAULICS

High-flow auxiliary hydraulics
3050 psi (210 bar) – 33.2 gpm (126 L/min)
Attachment case drain plumbing

ENGINE

Coolant block heater
Battery disconnect switch

OTHER

2 speed ground drive
Deluxe instrument panel
Road lights
Rotating beacon
Lift hooks
Special paint
Language decals
Factory-installed tires – see page 2
Buckets – see page 3
Bolt-on bucket cutting edges
42 in (1.07 m) and 48 in (1.22 m) pallet forks
Steel tracks



NOTE: All specifications are stated in accordance with SAE Standards or Recommended Practices, where applicable.

NOTE: All engines meet current EPA emissions requirements.

IMPORTANT: Case Construction Equipment Inc. reserves the right to change these specifications without notice and without incurring any obligation relating to such change. Case Construction Equipment Inc. does not warrant the safety or reliability of attachments from other manufacturers.

Case is a registered trademark of CNH America LLC. Any trademarks referred to herein, in association with goods and/or services of companies other than CNH America LLC, are the property of those respective companies.

Form No. CCE201009SR175
Replaces form no. None

Printed in U.S.A.
SR175 • Page 4 of 4



www.casece.com

© 2010 CNH America LLC
All Rights Reserved



All Case construction equipment is biodiesel ready.